

PRODUITS : Informations générales
Product information

DENOMINATION/ Name	PUREE POMME BANANE APPLE BANANA PUREE
INGREDIENTS	POMME HVE3 (79.9%), BANANE RUP (20%), ACIDE ASCORBIQUE (0,1%) APPLE HVE3 (79.9%), BANANA RUP (20%), ASCORBIC ACID (0.1%)
ORIGINE INGREDIENTS/ Ingredients Origin	France
POIDS NET/ Net Weight	3 kg
DDM / Shelf life (Date de Durabilité Minimale)	12 mois / month
CONDITIONS DE CONSERVATION AVANT OUVERTURE Storage conditions before opening	A conserver à température ambiante Stored at room temperature
CONDITIONS DE CONSERVATION APRES OUVERTURE Storage conditions after opening	A conserver au réfrigérateur et à consommer dans les 15 jours consume in the refrigerator and consume as you like during 15 days.
CODE ARTICLE	020453
EAN 13	3701259100820
DIMENSIONS DE L'UVC UVC's Dimension	315 x 250 mm

PRODUITS : CARACTERISTIQUE D'EMBALLAGE
SECONDAIRE
Parcel Information

COLISAGE / Parcel	4 UVC / COLIS (Parcel)
DIMENSIONS	385 X 265 X 145 mm
POIDS NET Net weight	12 kg
POIDS BRUT/ Brut weight	12,51 kg

VISUEL DE COLISAGE
Packaging view

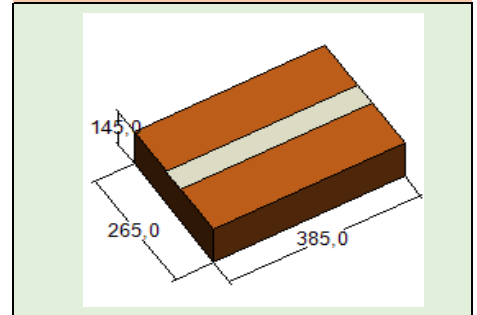

PRODUIT : visuel étiquette commerciale
Product label



PRODUITS : CARACTERISTIQUE D'EMBALLAGE
TERTIAIRE
Pallets information

PALETTISATION / Palletization	90 COLIS/ Parcels
DIMENSIONS	1200 x 800 x 1594 mm
POIDS NET Net weight	1080 Kg
POIDS BRUT poids palette inclus (25 Kg) Brut weight with pallets	1151 Kg
UVC / PALETTE UVC/ Pallets	360 UVC

VALEURS NUTRITIONNELLES ET ENERGETIQUES
Nutritional values

Valeurs nutritionnelles moyennes pour 100g Nutritional values for 100g	
Energie/ Energetic contribution:	251 KJ - 61 Kcal
Matière grasse/ Fat:	0,4 g
dont acide gras saturés/ Of which saturates	Négligeable
Glucides/ Carbohydrates	15 g
dont : sucre Of which sugar	13 g
Protéines/ Proteins	Négligeable
Sel/ Salt	Négligeable

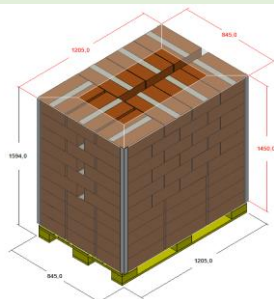

VISUEL DE PALETTISATION
Pallets view

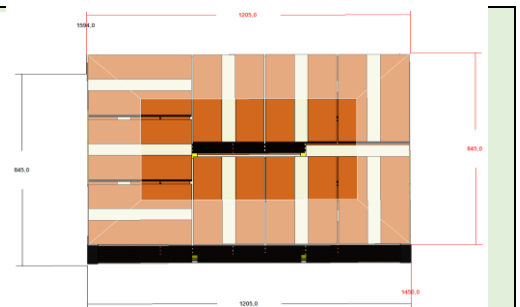

CERTIFICATION(S)

