

Denna handling får inte kopieras utan vårt skriftliga medgivande och dess innehåll får inte yppas för tredje man och inte heller användas för något obehörigt ändamål.

## Wacker R401/60 E

Material and size / Material, beteckning o dimension

Konstruerad av Granskad av Godkänd av - datum

TS 010312

INTERNATIONAL AB  
LUND SWEDEN

Description / Benämning

**Slang**

Drawing No. / Ritningsnummer

**4-7866**

Art. No. / Art. nr.

Generell tolerans  
SS-ISO 2768-1

Generell yt-  
jämnhet,  $R_a$

Vyplacering Scale / Skala

1:1

Utgåva

Blad

Ändr nr: Ändringens art / Ändringsmeddelande  
 A MB ändrat till RAL 9005 F Black  
 0184 Uppdaterad ritning

Godkänd av - datum  
 030915 ON  
 060911 UL

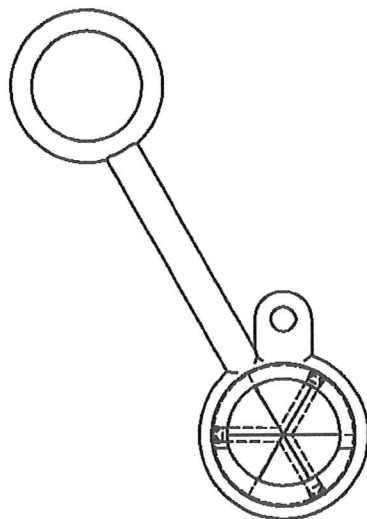
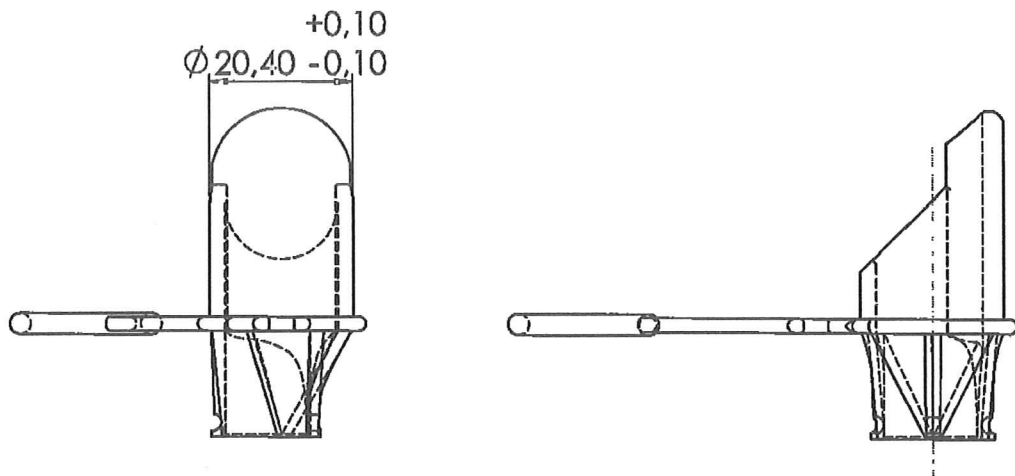

Cut 3x8mm with razorblade

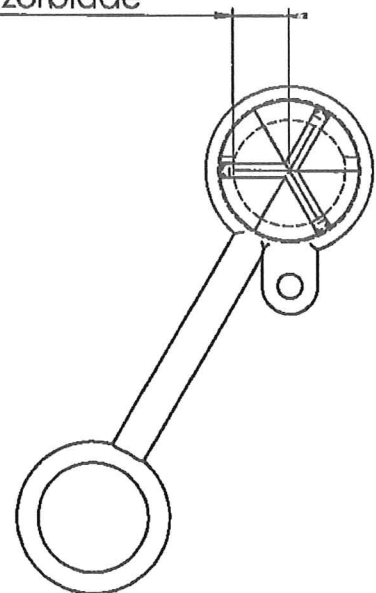

Weight  $6.7 \pm 0.1g$

Elastosil Wacker R401/60° + Elastosil Black RAL 9005 F

Material and size / Material, beteckning o dimension

Konstruerad av  
 SB 010314

Granskad av

Godkänd av - datum

Generell tolerans  
 SS-ISO 2768-1

Art. No. / Art. nr.

Generell yt-  
 jämnhet, R<sub>a</sub>

Vyplacering

Scale / Skala

1:1

Description / Benämning

**Munstycke**

Drawing No. / Ritningsnummer

**4-7914**

Utgåva

P1

Blad

INTERNATIONAL AB  
 LUND SWEDEN

Denna handling får inte kopieras utan vårt skriftliga medgivande och dess innehåll får inte yppas för tredje man och inte heller användas för något obehörigt ändamål.

# ELASTOSIL® R 401/60

## HIGH CONSISTENCY SILICONE RUBBER

### Product description

Vulcanizates made from this compound exhibit a unique combination of characteristics. They are noted for their good flexibility, high transparency, and mechanical properties. The compounds are easily pigmented with ELASTOSIL® PT Pigment Pastes and have good processing characteristics.

### Application

Postcured parts can be used for food contact applications and are suitable for use under the Recommendation "XV. Silicones" of the BfR and FDA § 177.2600 under observance of any given limitations on extractable and volatile substances.

### Storage

The 'Best use before end' date of each batch is shown on the product label.

Storage beyond the date specified on the label does not necessarily mean that the product is no longer usable. In this case however, the properties required for the intended use must be checked for quality assurance reasons.

### Safety notes

Comprehensive instructions are given in the corresponding Material Safety Data Sheets. They are available on request from WACKER subsidiaries or may be printed via WACKER web site <http://www.wacker.com>.

### Product data

Typical general characteristics	Inspection Method	Value
Appearance		transparent
Density at 20 °C	ISO 1183-1 A	approx. 1,15 g/cm <sup>3</sup>
<b>Curing agent E</b>		
Hardness Shore A	DIN 53505	61
Tensile strength	DIN 53504 S1 / ISO 37	11 N/mm <sup>2</sup>
Elongation at break	DIN 53504 S 1	440 %
Tear strength	ASTM D 624 B	24 N/mm
Rebound resilience	DIN 53512	57 %
Compression set	DIN ISO 815-B (22 h / 175 °C)	31 %
<b>Curing agent C1</b>		
Hardness Shore A	DIN 53505	62
Tensile strength	DIN 53504 S1 / ISO 37	11 N/mm <sup>2</sup>
Elongation at break	DIN 53504 S 1	530 %
Tear strength	ASTM D 624 B	26 N/mm
Rebound resilience	DIN 53512	56 %
Compression set	DIN ISO 815-B (22 h / 175 °C)	16 %

These figures are only intended as a guide and should not be used in preparing specifications.

**Cure conditions**

Curing agent		[%]	Cure	Post-cure
E	50 % paste of bis-(2,4-dichlorobenzoyl)-peroxide in silicone fluid	1.5	10 min / 135 °C	4 h / 200 °C
C1	Dicumyl peroxide (98 %)	0.7	15 min / 165 °C	4 h / 200 °C
C6	45 % paste of 2,5-bis-(t-butylperoxy)-2,5-dimethyl-hexane in silicone rubber	1.2	15 min / 165 °C	4 h / 200 °C

Curing Agent C6 yields similar values to those obtained with C1.

These figures are intended as a guide and should not be used in preparing specifications.

The data presented in this leaflet are in accordance with the present state of our knowledge, but do not absolve the user from carefully checking all supplies immediately on receipt. We reserve the right to alter product constants within the scope of technical progress or new developments. The recommendations made in this leaflet should be checked by preliminary trials because of conditions during processing over which we have no control, especially where other companies' raw materials are also being used. The recommendations do not absolve the user from the obligation of investigating the possibility of infringement of third parties' rights and, if necessary, clarifying the position. Recommendations for use do not constitute a warranty, either express or implied, of the fitness or suitability of the products for a particular purpose.

The management system has been certified according to DIN EN ISO 9001 and DIN EN ISO 14001

WACKER is a trademark of Wacker Chemie AG.  
ELASTOSIL® is a trademark of Wacker Chemie AG

For technical, quality, or product safety questions, please contact:

Wacker Chemie AG  
Hanns-Seidel-Platz 4  
81737 München, Germany  
info.silicones@wacker.com

[www.wacker.com](http://www.wacker.com)

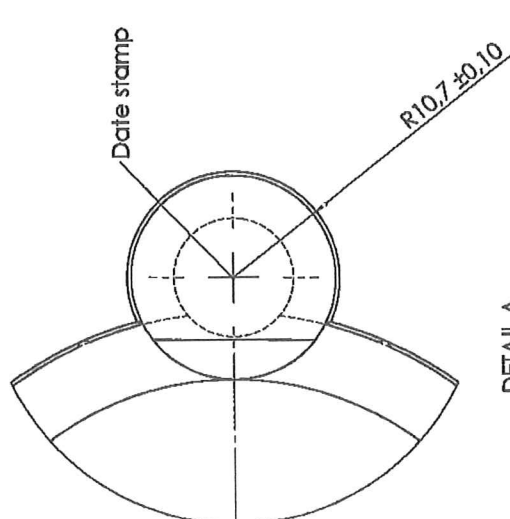
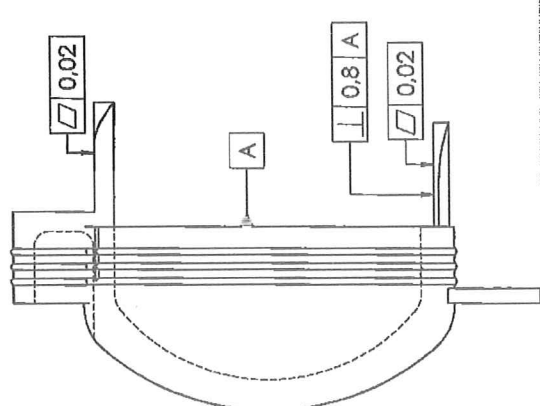
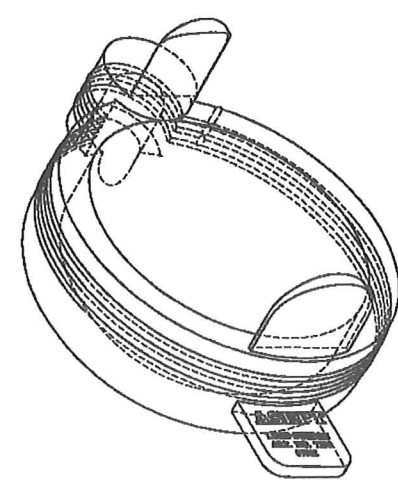
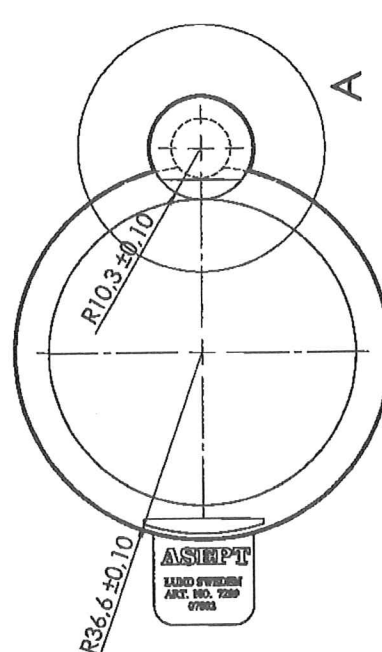
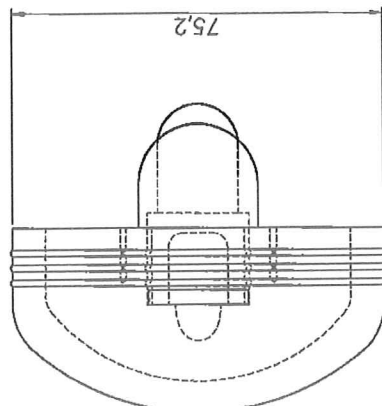
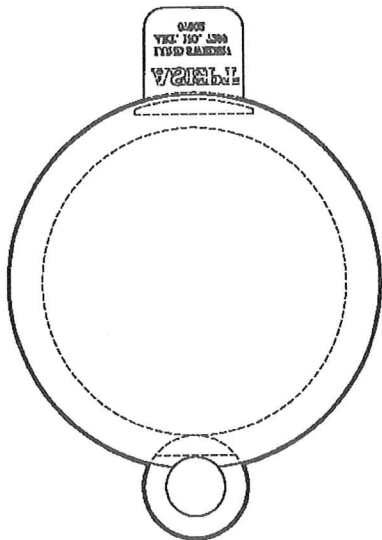

Vikt/Weight 73.2±0.2g

Material and size / Material, beteckning o dimension <b>Wacker LR3003-50° or TY 1841-50 /</b>		Art. No. / Art. nr. <b>7299</b>	
Designed by/Utvecklad av/ Granslad av <b>UL / 2011-03-28</b>		Generalist/Generell <b>ISO 27061 m.</b>	
Approved by/Godkänd av - data/datum		Moulding Scale / Skala <b>1:1</b>	
Description / Beskrivning <b>Dome</b>		Mould No. / Formnummer <b>V-704 P2</b>	
INTERNATIONAL AB www.asept.com		Revision <b>1/1</b>	

DETAIL A  
SCALE 2:1

# ELASTOSIL® LR 3003/50 A/B

LIQUID SILICONE RUBBER

## Product description

Liquid silicone rubbers of the ELASTOSIL® LR 3003 series are paste-like, easily-pigmentable two-component compounds with short curing times. Their vulcanizates are noted for their high transparency and excellent mechanical and electrical properties.

## Properties

The products can be used within a temperature range of - 55 °C to + 210 °C.

The addition of heat stabilizers at service temperatures of more than 180 °C is recommended. Further information to improve the heat stability by use of specific ELASTOSIL® FL Color Pastes can be obtained from the Technical Information Sheet "ELASTOSIL® FL Color Pastes".

## Application

These grades are particularly suitable for the economical production of large series of injection-moulded articles.

Parts made from ELASTOSIL® LR 3003/50 A/B can be used for technical applications. These articles are also suitable for use in conjunction with foodstuffs.

Postcured parts can be used for food contact applications and are suitable for use under the Recommendation "XV. Silicones" of the BfR and FDA § 177.2600 under observance of any given limitations on extractable and volatile substances.

## Processing

The A and B components are delivered ready to use in

20 and 200 litre drums. With adequate metering equipment, they can be pumped directly from the original containers into the injection molding machine and mixed by a static mixer. The mixing ratio is 1 : 1. At room temperature, mixtures of A and B components have a pot life of at least three days.

For detailed information refer to our brochure "SOLID AND LIQUID SILICONE RUBBER - MATERIAL AND PROCESSING GUIDELINES"

## Storage

The 'Best use before end' date of each batch is shown on the product label.

Storage beyond the date specified on the label does not necessarily mean that the product is no longer usable. In this case however, the properties required for the intended use must be checked for quality assurance reasons.

## Safety notes

Comprehensive instructions are given in the corresponding Material Safety Data Sheets. They are available on request from WACKER subsidiaries or may be printed via WACKER web site <http://www.wacker.com>.

## Product data

Typical general characteristics	Inspection Method	Value
Hardness Shore A	DIN 53505	50
Appearance		transparent
Density	ISO 1183-1 A	1,13 g/cm <sup>3</sup>
Viscosity (shear rate 0,9 s <sup>-1</sup> )	DIN 53019	912000 mPa s
Viscosity (shear rate 10 s <sup>-1</sup> )	DIN 53019	370000 mPa s
Tensile strength	DIN 53504 S 1	9,90 N/mm <sup>2</sup>
Elongation at break	DIN 53504 S 1	480 %
Tear strength	ASTM D 624 B	29 N/mm
Rebound resilience	DIN 53512	62 %
Compression set *	DIN ISO 815-B (22 h / 175 °C)	13 %
Dielectric strength (1-mm-sheet)	DIN IEC 243-2	23 kV/mm
Volume resistivity	DIN IEC 93	5 x 10 <sup>15</sup> Ω cm
Dielectric constant at 50 Hz	DIN VDE 0303	2,8 ε <sub>r</sub>
Dissipation Factor (50 Hz)	DIN VDE 0303	20 x 10 <sup>-4</sup> tan δ

Cure conditions: 5 min / 165 °C in press; postcuring for 4 h / 200 °C in ventilated air

\* Postcuring for CS: 6 h / 200 °C

These figures are only intended as a guide and should not be used in preparing specifications.

The data presented in this leaflet are in accordance with the present state of our knowledge, but do not absolve the user from carefully checking all supplies immediately on receipt. We reserve the right to alter product constants within the scope of technical progress or new developments. The recommendations made in this leaflet should be checked by preliminary trials because of conditions during processing over which we have no control, especially where other companies' raw materials are also being used. The recommendations do not absolve the user from the obligation of investigating the possibility of infringement of third parties' rights and, if necessary, clarifying the position. Recommendations for use do not constitute a warranty, either express or implied, of the fitness or suitability of the products for a particular purpose.

The management system has been certified according to DIN EN ISO 9001 and DIN EN ISO 14001

WACKER is a trademark of Wacker Chemie AG.  
ELASTOSIL® is a trademark of Wacker Chemie AG

For technical, quality, or product safety questions, please contact:

Wacker Chemie AG  
Hanns-Seidel-Platz 4  
81737 München, Germany  
info.silicones@wacker.com

www.wacker.com